

REVISONS		DATE	OWN	APVD
F3	SR10-0471-02	06-11-02	-	FB
F4	SR10-0177-03	11-08-03	-	KV
F5	ECR-08-031098	24-03-09	AEG	MKO

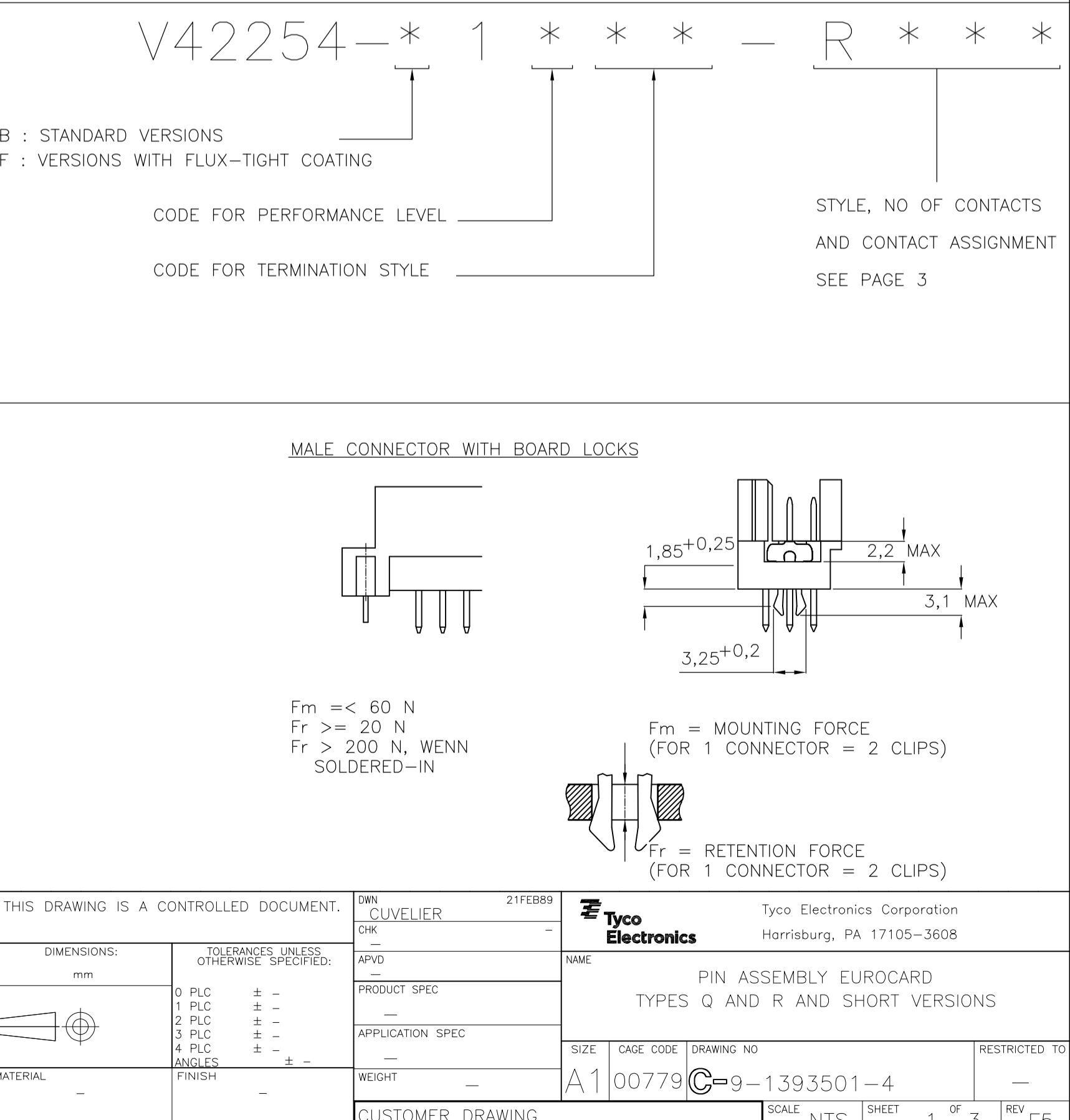

THIS INFORMATION IS CONFIDENTIAL AND PROPRIETARY TO TYCO ELECTRONICS CORPORATION AND ITS WORLDWIDE WORLDWIDE SUBSIDIARIES AND AFFILIATES. IT MAY NOT BE DISCLOSED TO ANYONE, OTHER THAN TYCO ELECTRONICS CORPORATION, WITHOUT WRITTEN AUTHORIZATION FROM TYCO ELECTRONICS CORPORATION, HARRISBURG, PENNSYLVANIA USA.

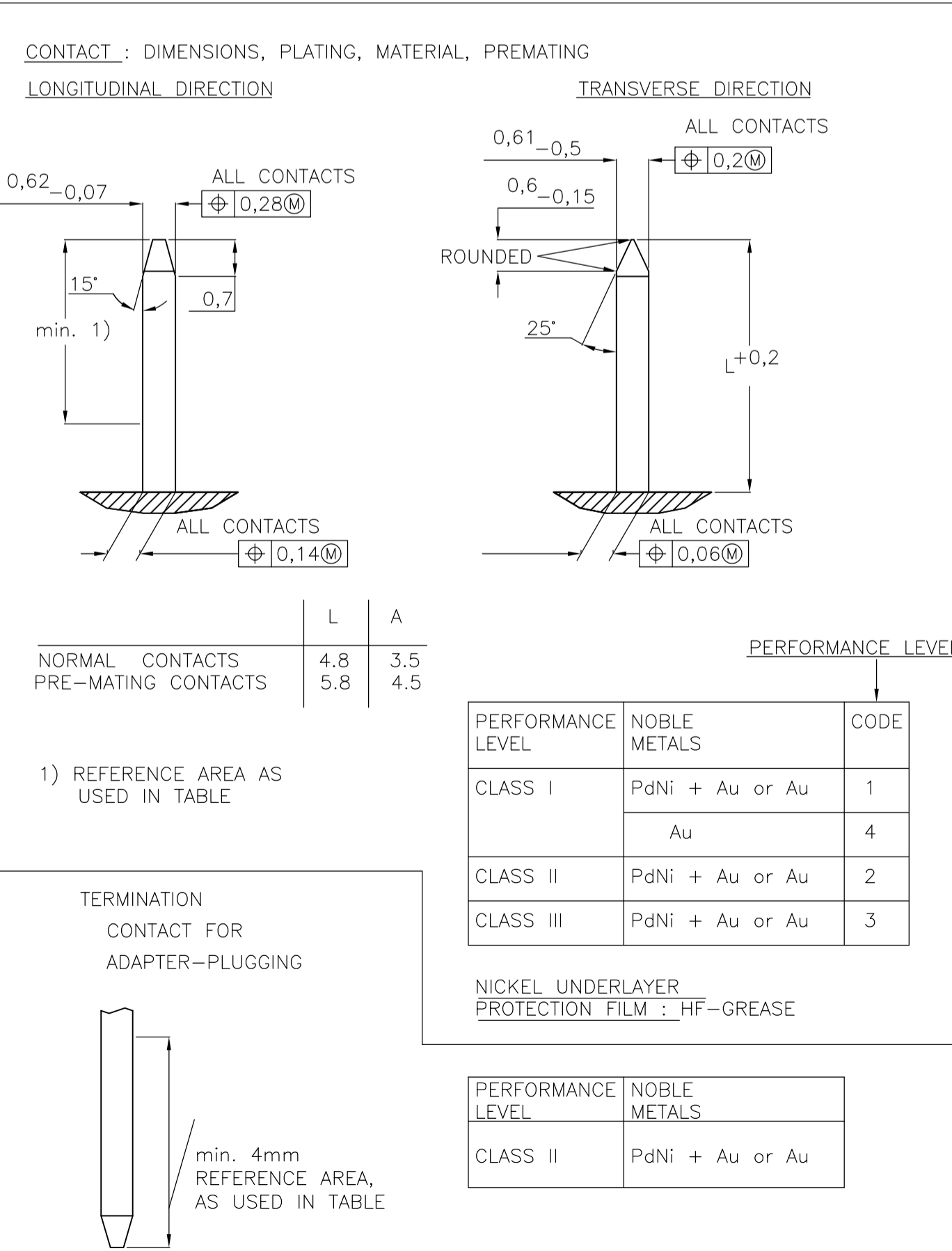
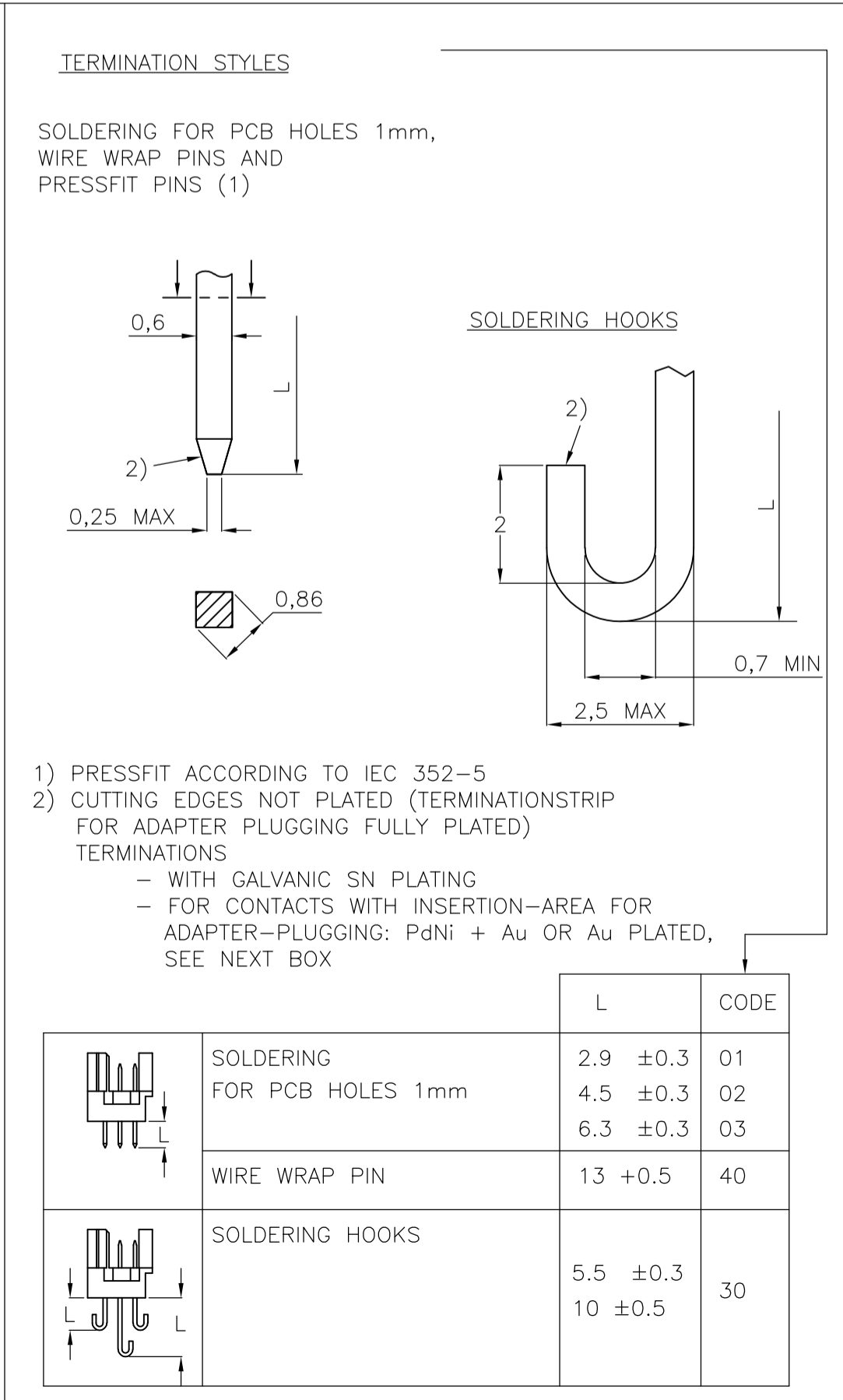
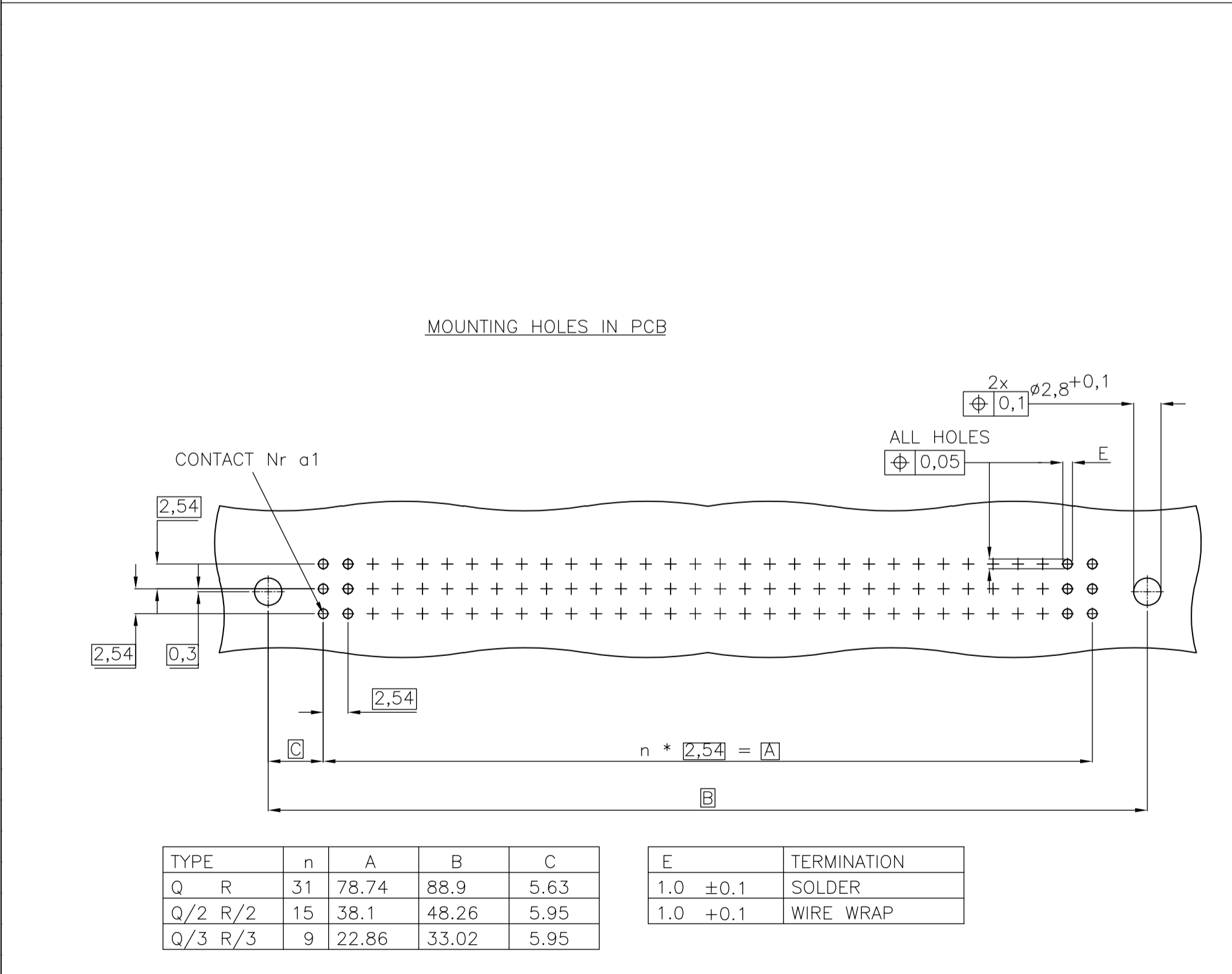
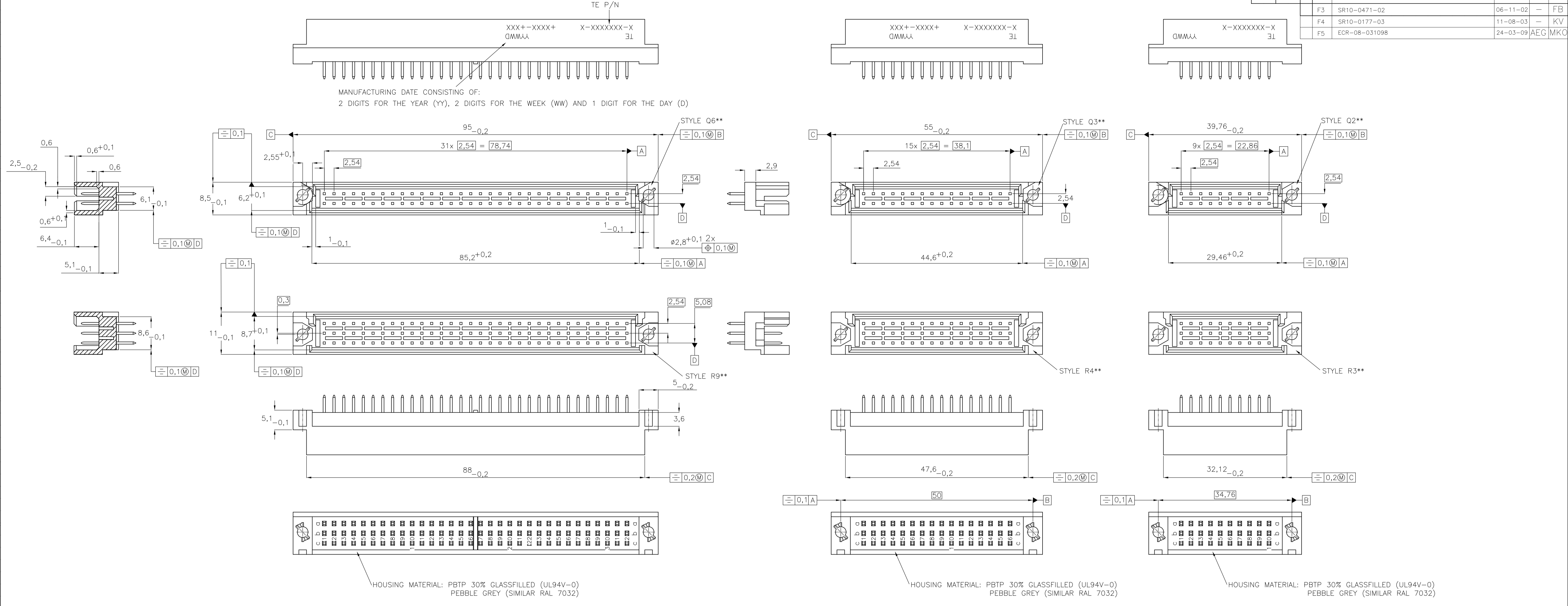
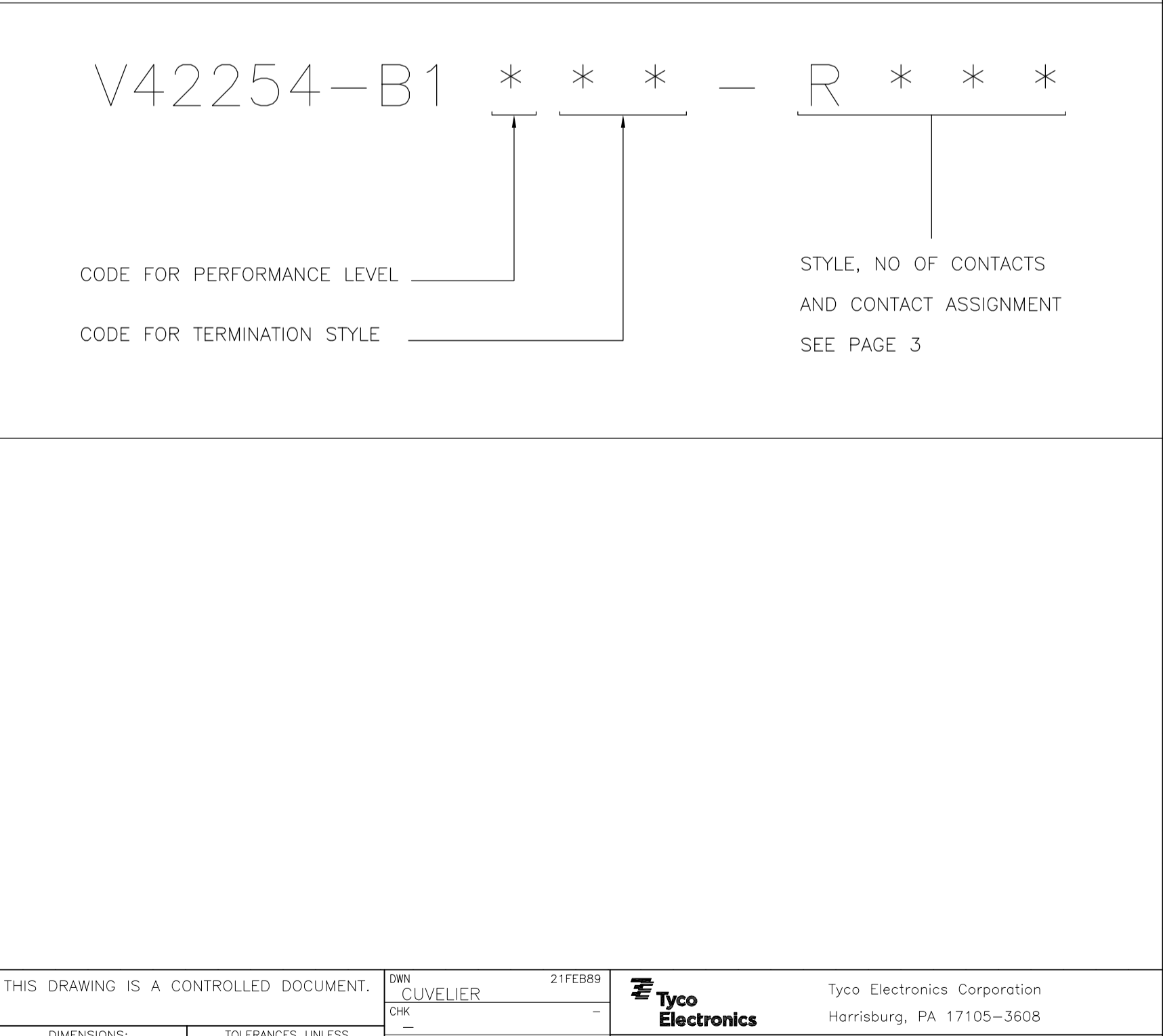
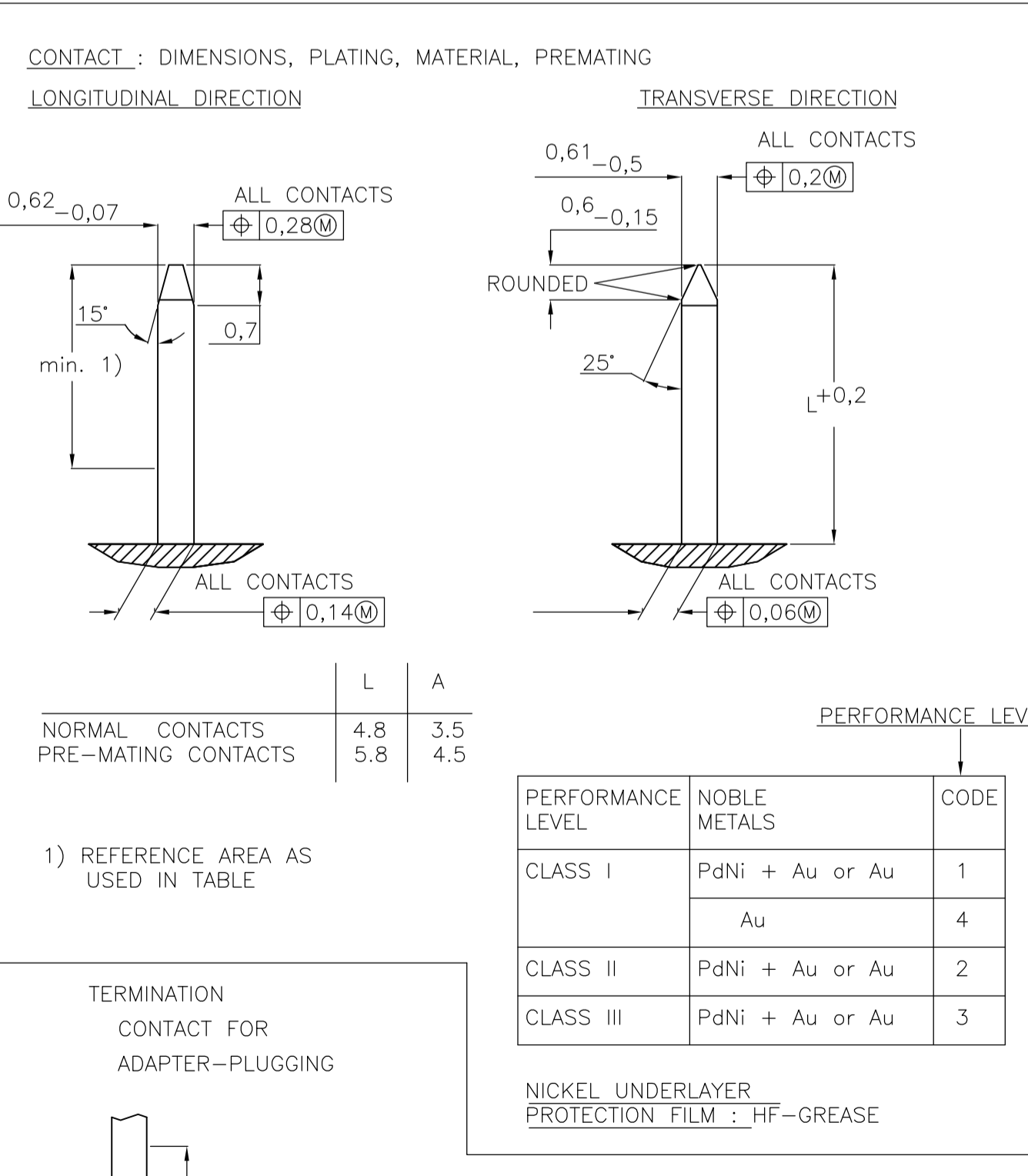
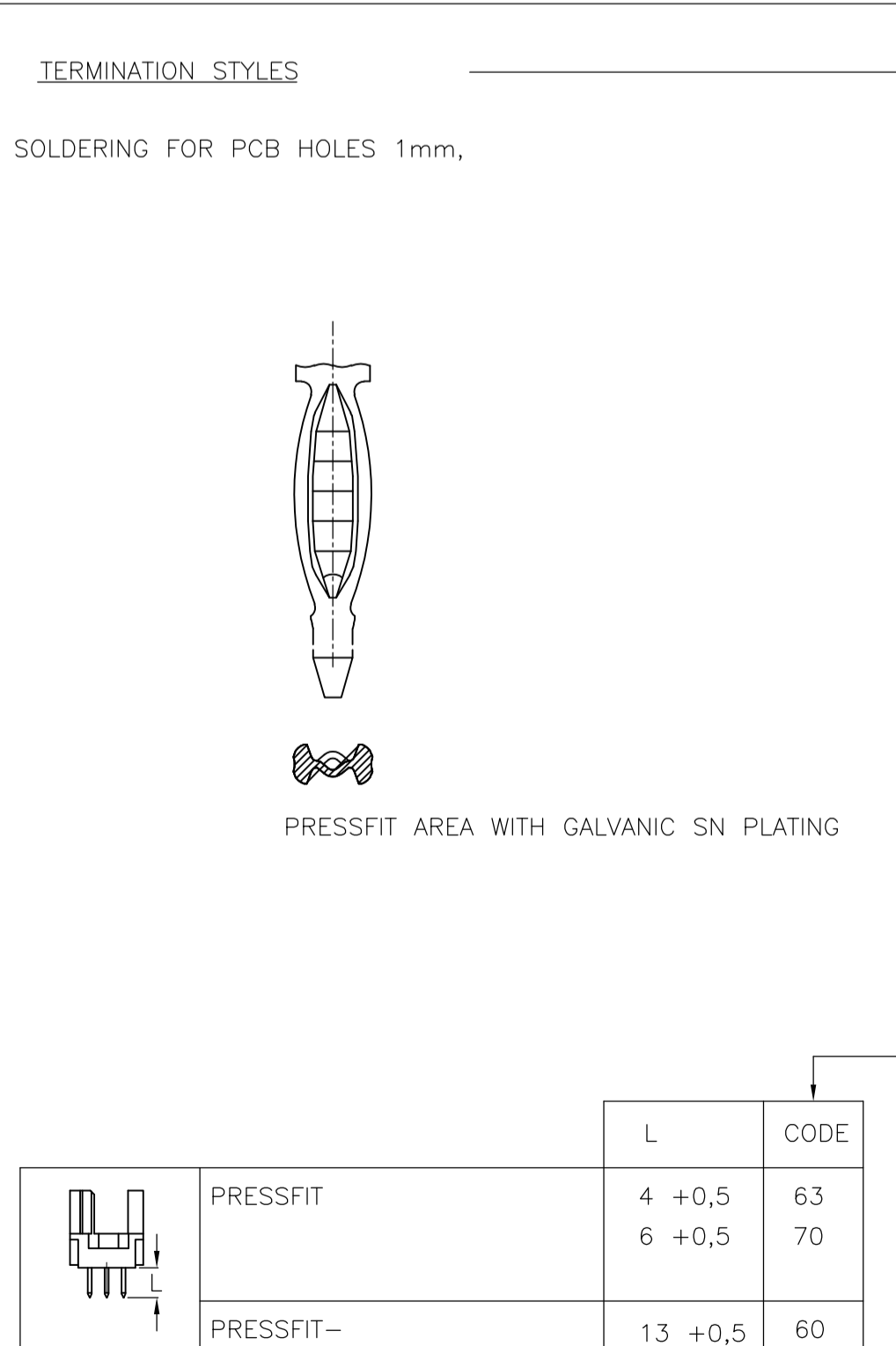
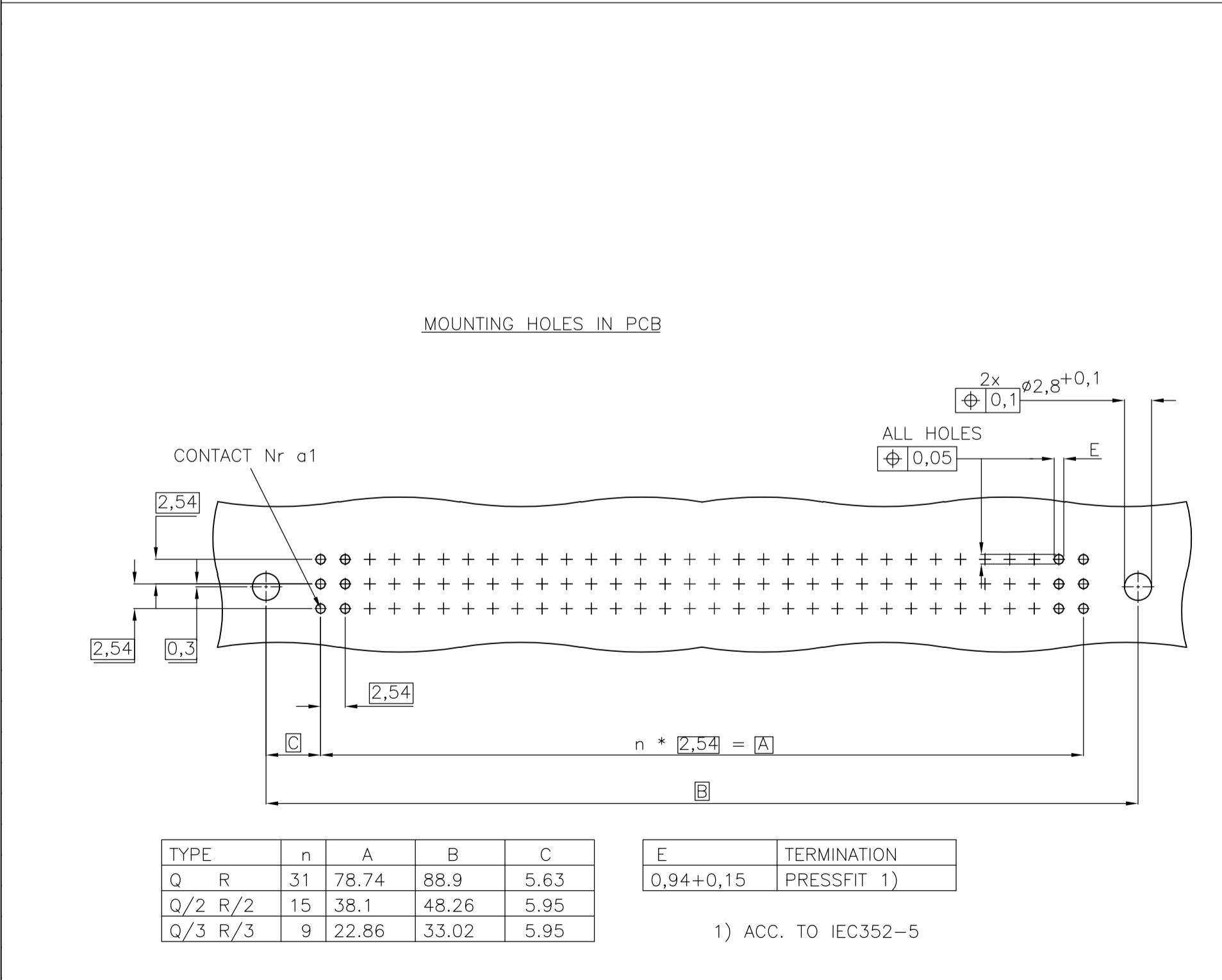
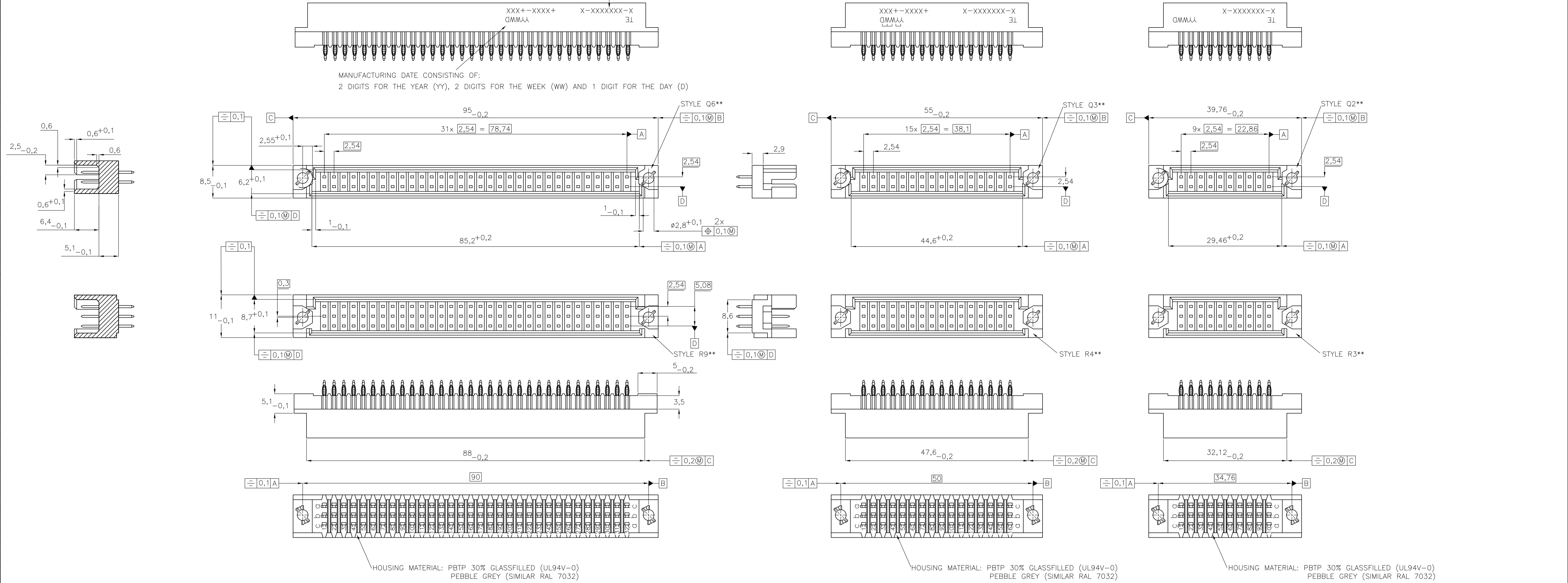

THIS INFORMATION IS CONFIDENTIAL AND PROPRIETARY TO TYCO ELECTRONICS CORPORATION AND ITS WORLDWIDE SUBSIDIARIES AND AFFILIATES. IT MAY NOT BE DISCLOSED TO ANYONE, OTHER THAN TYCO ELECTRONICS CORPORATION, WITHOUT WRITTEN AUTHORIZATION FROM TYCO ELECTRONICS CORPORATION, HARRISBURG, PENNSYLVANIA USA.

PRODUCT DESCRIPTION CODE	TYCO ELECTRONICS PART NUMBER	STYLE & NUMBER OF POSITIONS	TERMINATION POSTS	LOADED ROWS	STANDARD PRE-MATING (1 MM 1)	PERFORMANCE LEVEL	BOARD LOCKS
V42254B1101Q210	1393659-2	Q20	2,9mm STRAIGHT SOLDER LEADS	EVERY ROW , EVERY PITCH	NO	1	YES
V42254B1101R480	1393659-3	R48	2,9mm STRAIGHT SOLDER LEADS	EVERY ROW , EVERY PITCH	NO	1	NO
V42254B1101R960	1393659-4	R96	2,9mm STRAIGHT SOLDER LEADS	EVERY ROW , EVERY PITCH	NO	1	NO
V42254B1101R963	1393659-5	R96	2,9mm STRAIGHT SOLDER LEADS	ROW A+C , EVERY PITCH	NO	1	NO
V42254B1101R968	1393659-6	R96	2,9mm STRAIGHT SOLDER LEADS	ROW A+C , EVERY EVEN PITCH	NO	1	NO
V42254B1102Q200	1393659-7	Q20	4,5mm STRAIGHT SOLDER LEADS	EVERY ROW , EVERY PITCH	NO	1	NO
V42254B1102Q320	1393659-8	Q32	4,5mm STRAIGHT SOLDER LEADS	EVERY ROW , EVERY PITCH	NO	1	NO
V42254B1102R480	1393659-9	R48	4,5mm STRAIGHT SOLDER LEADS	EVERY ROW , EVERY PITCH	NO	1	NO
V42254B1102R960	1-1393659-0	R96	4,5mm STRAIGHT SOLDER LEADS	EVERY ROW , EVERY PITCH	NO	1	NO
V42254B1102R960H	1-1393659-1	R96	4,5mm STRAIGHT SOLDER LEADS	EVERY ROW , EVERY PITCH	NO	1	NO
V42254B1103R960	1-1393659-2	R96	6,3mm STRAIGHT SOLDER LEADS	EVERY ROW , EVERY PITCH	NO	1	NO
V42254B1140Q640	1-1393659-5	Q64	13mm STRAIGHT WIRE-WRAP PINS	EVERY ROW , EVERY PITCH	NO	1	NO
V42254B1140R480	1-1393659-6	R48	13mm STRAIGHT WIRE-WRAP PINS	EVERY ROW , EVERY PITCH	NO	1	NO
V42254B1161R960	1393658-1	R96	17mm PRESS-IN TERMINALS WITH WIRE-WRAP	EVERY ROW , EVERY PITCH	NO	1	NO
V42254B1201Q200	2-1393659-0	Q20	2,9mm STRAIGHT SOLDER LEADS	EVERY ROW , EVERY PITCH	NO	2	NO
V42254B1201Q320	2-1393659-1	Q32	2,9mm STRAIGHT SOLDER LEADS	EVERY ROW , EVERY PITCH	NO	2	NO
V42254B1201Q640	2-1393659-2	Q64	2,9mm STRAIGHT SOLDER LEADS	EVERY ROW , EVERY PITCH	NO	2	NO
V42254B1201R300	2-1393659-3	R30	2,9mm STRAIGHT SOLDER LEADS	EVERY ROW , EVERY PITCH	NO	2	NO
V42254B1201R303	2-1393659-4	R30	2,9mm STRAIGHT SOLDER LEADS	ROW A+C , EVERY PITCH	NO	2	NO
V42254B1201R410	2-1393659-5	R48	2,9mm STRAIGHT SOLDER LEADS	EVERY ROW , EVERY PITCH	NO	2	YES
V42254B1201R480	2-1393659-6	R48	2,9mm STRAIGHT SOLDER LEADS	EVERY ROW , EVERY PITCH	NO	2	NO
V42254B1201R913	2-1393659-7	R96	2,9mm STRAIGHT SOLDER LEADS	ROW A+C , EVERY PITCH	NO	2	YES
V42254B1201R960	2-1393659-8	R96	2,9mm STRAIGHT SOLDER LEADS	EVERY ROW , EVERY PITCH	NO	2	NO
V42254B1201R963	2-1393659-9	R96	2,9mm STRAIGHT SOLDER LEADS	ROW A+C , EVERY PITCH	NO	2	NO
V42254B1201R968	3-1393659-0	R96	2,9mm STRAIGHT SOLDER LEADS	ROW A+C , EVERY EVEN PITCH	NO	2	NO
V42254B1202Q320	3-1393659-1	Q32	4,5mm STRAIGHT SOLDER LEADS	EVERY ROW , EVERY PITCH	NO	2	NO
V42254B1202Q320N	3-1393659-2	Q32	4,5mm STRAIGHT SOLDER LEADS	EVERY ROW , EVERY PITCH	NO	2	NO
V42254B1202Q640	3-1393659-4	Q64	4,5mm STRAIGHT SOLDER LEADS	EVERY ROW , EVERY PITCH	NO	2	NO
V42254B1202R300	3-1393659-5	R30	4,5mm STRAIGHT SOLDER LEADS	EVERY ROW , EVERY PITCH	NO	2	NO
V42254B1202R303	3-1393659-6	R30	4,5mm STRAIGHT SOLDER LEADS	ROW A+C , EVERY PITCH	NO	2	NO
V42254B1202R410	3-1393659-7	R48	4,5mm STRAIGHT SOLDER LEADS	EVERY ROW , EVERY PITCH	NO	2	YES
V42254B1202R480	3-1393659-9	R48	4,5mm STRAIGHT SOLDER LEADS	EVERY ROW , EVERY PITCH	NO	2	NO
V42254B1202R483	4-1393659-0	R48	4,5mm STRAIGHT SOLDER LEADS	ROW A+C , EVERY PITCH	NO	2	NO
V42254B1202R910	4-1393659-1	R96	4,5mm STRAIGHT SOLDER LEADS	EVERY ROW , EVERY PITCH	NO	2	YES
V42254B1202R913	4-1393659-2	R96	4,5mm STRAIGHT SOLDER LEADS	ROW A+C , EVERY PITCH	NO	2	YES
V42254B1202R930	4-1393659-3	R96	4,5mm STRAIGHT SOLDER LEADS	EVERY ROW , EVERY PITCH	YES	2	NO
V42254B1202R933	4-1393659-4	R96	4,5mm STRAIGHT SOLDER LEADS	ROW A+C , EVERY PITCH	YES	2	NO
V42254B1202R960	4-1393659-5	R96	4,5mm STRAIGHT SOLDER LEADS	EVERY ROW , EVERY PITCH	NO	2	NO
V42254B1202R960N	4-1393659-6	R96	4,5mm STRAIGHT SOLDER LEADS	EVERY ROW , EVERY PITCH	NO	2	NO
V42254B1202R963	4-1393659-7	R96	4,5mm STRAIGHT SOLDER LEADS	ROW A+C , EVERY PITCH	NO	2	NO
V42254B1202R965	4-1393659-8	R96	4,5mm STRAIGHT SOLDER LEADS	EVERY ROW , EVERY EVEN PITCH	NO	2	NO
V42254B1202R968	4-1393659-9	R96	4,5mm STRAIGHT SOLDER LEADS	ROW A+C , EVERY EVEN PITCH	NO	2	NO
V42254B1203R963	5-1393659-0	R96	6,3mm STRAIGHT SOLDER LEADS	ROW A+C , EVERY PITCH	NO	2	NO
V42254B1230R303	5-1393659-1	R30	5,5/10mm SOLDER HOOKS	ROW A+C , EVERY PITCH	NO	2	NO
V42254B1230R960	5-1393659-3	R96	5,5/10mm SOLDER HOOKS	EVERY ROW , EVERY PITCH	NO	2	NO
V42254B1230R963	5-1393659-4	R96	5,5/10mm SOLDER HOOKS	ROW A+C , EVERY PITCH	NO	2	NO
V42254B1240Q640	5-1393659-6	Q64	13mm STRAIGHT WIRE-WRAP PINS	EVERY ROW , EVERY PITCH	NO	2	NO
V42254B1240R300	5-1393659-7	R30	13mm STRAIGHT WIRE-WRAP PINS	EVERY ROW , EVERY PITCH	NO	2	NO
V42254B1240R960	5-1393659-8	R96	13mm STRAIGHT WIRE-WRAP PINS	EVERY ROW , EVERY PITCH	NO	2	NO
V42254B1240R963	5-1393659-9	R96	13mm STRAIGHT WIRE-WRAP PINS	ROW A+C , EVERY PITCH	NO	2	NO
V42254B1260R483	1393658-2	R48	13mm PRESS-IN TERMINALS WITH WIRE-WRAP	ROW A+C , EVERY PITCH	NO	2	NO
V42254B1260R960	1393658-3	R96	13mm PRESS-IN TERMINALS WITH WIRE-WRAP	EVERY ROW , EVERY PITCH	NO	2	NO
V42254B1260R963	1393658-5	R96	13mm PRESS-IN TERMINALS WITH WIRE-WRAP	ROW A+C , EVERY PITCH	NO	2	NO
V42254B1261R480	1393658-7	R48	17mm PRESS-IN TERMINALS WITH WIRE-WRAP	EVERY ROW , EVERY PITCH	NO	2	NO
V42254B1263Q320	9-1393501-4	Q32	3,7mm PRESS-IN TERMINALS	EVERY ROW , EVERY PITCH	NO	2	NO
V42254B1263Q640	1393658-9	Q64	3,7mm PRESS-IN TERMINALS	EVERY ROW , EVERY PITCH	NO	2	NO
V42254B1263R300	1-1393658-0	R30	3,7mm PRESS-IN TERMINALS	EVERY ROW , EVERY PITCH	NO	2	NO
V42254B1263R300*40	1-1393658-1	R30	3,7mm PRESS-IN TERMINALS	EVERY ROW , EVERY PITCH	NO	2	NO
V42254B1263R330	9-1393501-5	R30	3,7mm PRESS-IN TERMINALS	EVERY ROW , EVERY PITCH	YES	2	NO
V42254B1263R480	1-1393658-2	R48	3,7mm PRESS-IN TERMINALS	EVERY ROW , EVERY PITCH	NO	2	NO
V42254B1263R483	1-1393658-3	R48	3,7mm PRESS-IN TERMINALS	ROW A+C , EVERY PITCH	NO	2	NO
V42254B1263R960	1-1393658-4	R96	3,7mm PRESS-IN TERMINALS	EVERY ROW , EVERY PITCH	NO	2	NO
V42254B1263R963	1-1393658-5	R96	3,7mm PRESS-IN TERMINALS	ROW A+C , EVERY PITCH	NO	2	NO
V42254B1266R300	1-1393658-6	R30	13mm PRESS-IN TERMINALS WITH WIRE-WRAP AN ADAPTER INSERTION AREA	EVERY ROW , EVERY PITCH	NO	2	NO
V42254B1266R483	1-1393658-7	R48	13mm PRESS-IN TERMINALS WITH WIRE-WRAP AN ADAPTER INSERTION AREA	ROW A+C , EVERY PITCH	NO	2	NO
V42254B1266R960	1-1393658-8	R96	13mm PRESS-IN TERMINALS WITH WIRE-WRAP AN ADAPTER INSERTION AREA	EVERY ROW , EVERY PITCH	NO	2	NO
V42254B1266R963	1-1393658-9	R96	13mm PRESS-IN TERMINALS WITH WIRE-WRAP AN ADAPTER INSERTION AREA	ROW A+C , EVERY PITCH	NO	2	NO
V42254B1270R300	3-139-6	R30	6,0mm PRESS-IN TERMINALS FOR PCB-THICKNESS >=2,2mm	EVERY ROW , EVERY PITCH	NO	2	NO
V42254B1270R960	2-1393658-1	R96	6,0mm PRESS-IN TERMINALS FOR PCB-THICKNESS >=2,2mm	EVERY ROW , EVERY PITCH	NO	2	NO
V42254B1270R963	2-1393658-2	R96	6,0mm PRESS-IN TERMINALS FOR PCB-THICKNESS >=2,2mm	ROW A+C , EVERY PITCH	NO	2	NO
V42254B1270R968	2-1393658-3	R96	6,0mm PRESS-IN TERMINALS FOR PCB-THICKNESS >=2,2mm	ROW A+C , EVERY EVEN PITCH	NO	2	NO
V42254B1468R960	3-1393658-8	R96	20mm PRESS-IN TERMINALS WITH WIRE-WRAP AN ADAPTER INSERTION AREA	EVERY ROW , EVERY PITCH	NO	1	NO
V42254F1101R480	7-1393659-4	R48	2,9mm STRAIGHT SOLDER LEADS	EVERY ROW , EVERY PITCH	NO	1	NO
V42254F1201R410	7-1393659-5	R48	2,9mm STRAIGHT SOLDER LEADS	EVERY ROW , EVERY PITCH	NO	2	YES

4) ACCORDING TO BT 222 LEVEL 1.  
 3) CONNECTORS WITH FLUX-TIGHT COATING.  
 2) NO COMPANY NAME MARKED ON THE CONNECTOR.  
 1) FIRST AND LAST CONTACT OF EACH LOADED ROW IS A PRE-MATING (MAKE FIRST / BREAK LAST) CONTACT.  
 ACTIVE PART NUMBERS.  
 CONTACT TYCO ELECTRONICS FOR OTHER CONFIGURATION AVAILABILITY.

THIS INFORMATION IS CONFIDENTIAL AND PROPRIETARY TO TYCO ELECTRONICS CORPORATION AND ITS WORLDWIDE WORLDWIDE SUBSIDIARIES AND AFFILIATES. IT MAY NOT BE DISCLOSED TO ANYONE, OTHER THAN TYCO ELECTRONICS CORPORATION, WITHOUT WRITTEN AUTHORIZATION FROM TYCO ELECTRONICS CORPORATION, HARRISBURG, PENNSYLVANIA USA.

THIS DRAWING IS A CONTROLLED DOCUMENT.		DWN CUVELIER	21FEB89	Tyco Electronics Corporation Harrisburg, PA 17105-3608
DIMENSIONS: mm		CHK ---	---	
		TOLERANCES UNLESS OTHERWISE SPECIFIED:		NAME PIN ASSEMBLY EUROCARD TYPES Q AND R AND SHORT VERSIONS
MATERIAL ---		FINISH ---		PRODUCT SPEC ---
		WEIGHT ---		APPLICATION SPEC ---
		SCALE NTS		RESTRICTED TO ---
		SHEET 3 OF 3		REV F5
		CUSTOMER DRAWING		